

Power Brake Booster w/Master Cylinder

GM A & F Body

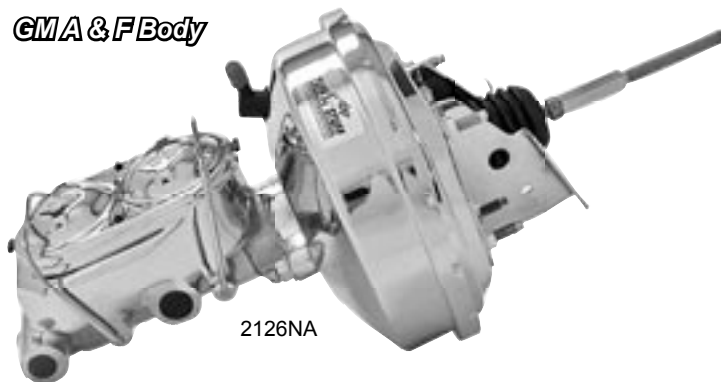

2126NA

GM A & F Body

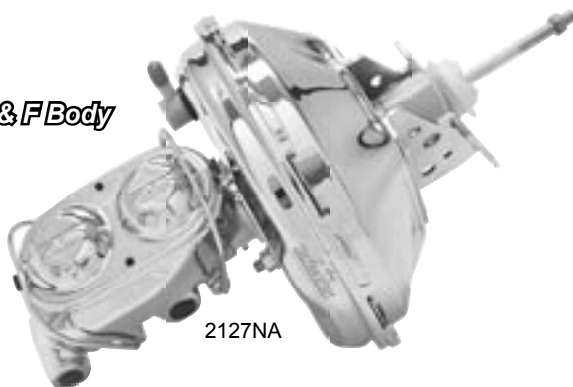

2127NA

Nova



2133NA

GM Truck



2132NA

- Specific fit applications available in beautiful chrome plated or gold zinc finishes
- 1" and 1-1/8" master cylinder bores work with disc/disc, disc/drum, and drum/drum brake set-ups
- Single and dual diaphragm styles available in 7", 8", 9" and 11" diameters to fit virtually all hot rods, customs and muscle cars
- 100% all new components - and every unit is vacuum tested to insure reliability
- Works with many stock mounting bracket set-ups and with Tuff Stuff bracket kits on page 36

GM A & F Body 1964 - 66

Style 2126N

9" Single Diaphragm Booster Combo, 3/8"-16 studs

Master Cylinder	Bore	Chrome	Gold Zinc
2071 Single reservoir	1-1/8"	2126NA	2126NB
2020 Dual reservoir	1"	2126NA-1	2126NB-1
2018 Dual reservoir	1"	2126NA-2	2126NB-2

7-1/8 long pedal rod, 1-1/2" vertical mounting hole spacing

GM A & F Body 1966 - 72

Style 2127N

11" Single Diaphragm Booster Combo, 3/8"-16 stud

Master Cylinder	Bore	Chrome	Gold Zinc
2071 Dual reservoir	1-1/8"	2127NA	2127NB
2020 Dual reservoir	1"	2127NA-1	2127NB-1
2018 Dual reservoir	1"	2127NA-2	2127NB-2

Chevy Nova 1962 - 67

Style 2133N

9" Single Diaphragm Booster Combo, 3/8"-16 studs

Master Cylinder	Bore	Chrome	Gold Zinc
2071 Dual reservoir	1-1/8"	2133NA	2133NB
2020 Dual reservoir	1"	2133NA-1	2133NB-1
2018 Dual reservoir	1"	2133NA-2	2133NB-2

3 Mounting studs

GM Truck 1973 - 92

Style 2132N

11" Dual Diaphragm Booster Combo, 10x1.5 metric

Master Cylinder	Bore	Chrome	Gold Zinc
2071 Single reservoir	1"-1/8"	2132NA	2132NB
2020 Dual reservoir	1"	2132NA-1	2132NB-1
2018 Dual reservoir	1"	2132NA-2	2132NB-2

3/8-16 Pedal rod length

Power Brake Booster w/Master Cylinder

- Specific fit applications available in beautiful chrome plated or gold zinc finishes
- 1" and 1-1/8" master cylinder bores work with disc/disc, disc/drum, and drum/drum brake set-ups
- Single and dual diaphragm styles available in 7", 8", 9" and 11" diameters to fit virtually all hot rods, customs and muscle cars
- 100% all new components - and every unit is vacuum tested to insure reliability
- Works with many stock mounting bracket set-ups and with Tuff Stuff bracket kits on page 36

100% New Parts

Corvette 1963 - 67 Style 2130N

9" Single Diaphragm Booster Combo, 3/8"-16 studs

Master Cylinder	Bore	Chrome	Gold Zinc
2071 Dual reservoir*	1-1/8"	2130NA	2130NB
2020 Dual reservoir	1"	2130NA-1	2130NB-1
2018 Dual reservoir	1"	2130NA-2	2130NB-2

*With four wheel disc brakes

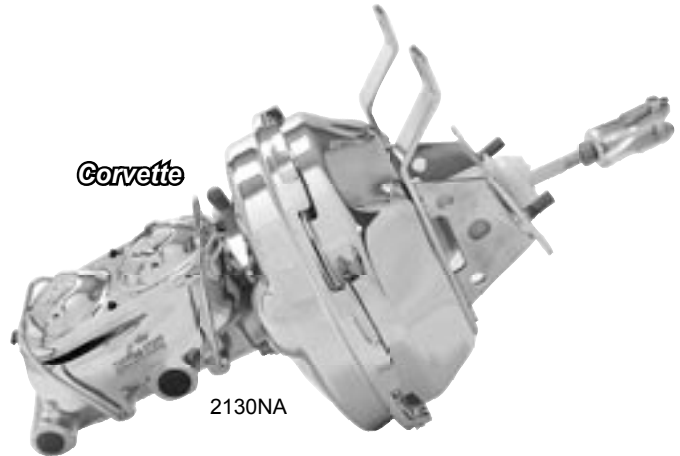

Corvette 1968 - 82 w/Y-7 rod kit Style 2129N

9" Dual Diaphragm Booster Combo, 10x1.5 metric

Master Cylinder	Bore	Chrome	Gold Zinc
2071 Dual reservoir	1-1/8"	2129NA	2129NB
2020 Dual reservoir	1"	2129NA-1	2129NB-1
2018 Dual reservoir	1"	2129NA-2	2129NB-2

With four wheel disc brakes, 3/8-24 pedal rod threads

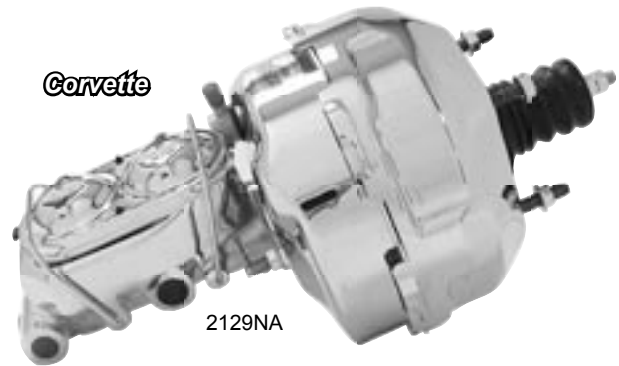

Ford Mustang 1967 - 70 Style 2125N

9" Single Diaphragm Booster Combo, 3/8"-16 studs

Master Cylinder	Bore	Chrome	Black
2071 Dual reservoir	1-1/8"	2125NA	2125NB
2020 Dual reservoir	1"	2125NA-1	2125NB-1
2018 Dual reservoir	1"	2125NA-2	2125NB-2
2017 Dual reservoir	1"	2125NA-3	2125NB-3

5 Mounting studs - one is offset

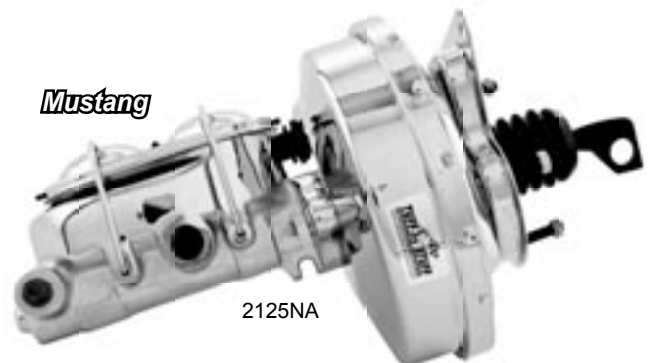

Jeep CJ 1974 - 86 Style 2131N

9" Single Slim Line Diaphragm Booster Combo

Master Cylinder	Bore	Chrome	Gold
2071 Dual reservoir	1-1/8"	2131NAJ	2131NBj
2020 Dual reservoir	1"	2131NAJ-1	2131NBj-1
2018 Dual reservoir	1"	2131NAJ-2	2131NBj-2

Includes mounting bracket

Power Brake Booster w/Master Cylinder



2121NA

- Universal fit applications available in beautiful chrome plated or gold zinc finishes
- 1" and 1-1/8" master cylinder bores work with disc/disc, disc/drum, and drum/drum brake set-ups
- Single and dual diaphragm styles available in 7", 8", 9" and 11" diameters to fit virtually all hot rods, customs and muscle cars
- 100% all new components - and every unit is vacuum tested to insure reliability
- Includes 3/8"-16 mounting studs and nuts
- Works with many stock mounting bracket set-ups and with Tuff Stuff bracket kits on page 36



2122NA

7" Booster Combo		Style 2121N & 2122N			
Universal		Single Diaphragm		Dual Diaphragm	
Master Cylinder	Bore	Chrome	Gold Zinc	Chrome	Gold Zinc
2071 Dual reservoir	1-1/8"	2121NA	2121NB	2122NA	2122NB
2020 Dual reservoir	1"	2121NA-1	2121NB-1	2122NA-1	2122NB-1
2018 Dual reservoir	1"	2121NA-2	2121NB-2	2122NA-2	2122NB-2
2017 Dual reservoir	1"		2121NB-3	2122NA-3	2122NB-3



2123NA

8" Booster Combo		Style 2123N	
Universal dual diaphragm			
Master Cylinder	Bore	Chrome	Gold Zinc
2071 Dual reservoir	1-1/8"	2123NA	2123NB
2020 Dual reservoir	1"	2123NA-1	2123NB-1
2018 Dual reservoir	1"	2123NA-2	2123NB-2
2017 Dual reservoir	1"	2123NA-3	
2150 Single reservoir	1"	2123NA-4	



2131NA

9" Booster Combo		Style 2131N & 2124N			
Universal		Single Slim Diaphragm		Dual Diaphragm	
Master Cylinder	Bore	Chrome	Gold	Chrome	Gold
2071 Dual reservoir	1-1/8"	2131NA	2131NB	2124NA	2124NB
2020 Dual reservoir	1"	2131NA-1	2131NB-1	2124NA-1	2124NB-1
2018 Dual reservoir	1"	2131NA-2	2131NB-2	2124NA-2	2124NB-2



2124NA

11" Booster Combo		Style 2128N	
Universal single diaphragm			
Master Cylinder	Bore	Chrome	Gold
2071 Dual reservoir	1-1/8"	2128NA	2128NB
2020 Dual reservoir	1"	2128NA-1	2128NB-1
2018 Dual reservoir	1"	2128NA-2	2128NB-2

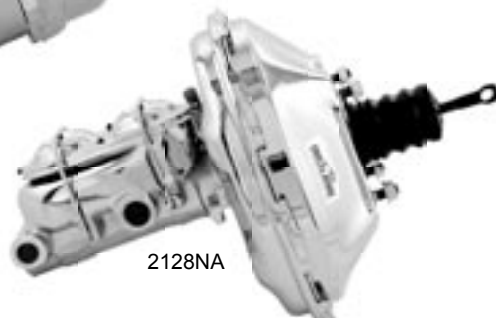

2128NA

Power Brake Boosters

- Universal and specific fit applications available in beautiful chrome plated, gold zinc and a variety of colors
- Single and dual diaphragm styles available in 7", 8", 9" and 11" diameters to fit virtually all hot rods, customs and muscle cars
- Every unit is vacuum tested to insure reliability
- Includes 3/8"-16 mounting studs and nuts where applicable
- Works with many stock mounting bracket set-ups and with Tuff Stuff bracket kits on page 36

100% New Parts

7" & 8" Universal Power Brake Boosters 2221, 2222 & 2223

7" & 8" Diaphragm	7" Diaphragm		8" Diaphragm
Finish	Single	Dual	Dual
Chrome	2221NA	2222NA	2223NA
Gold zinc	2221NB	2222NB	2223NB
Black	2221NC	2222NC	2223NC
Yellow		2222NCYELLOW	2223NCYELLOW
Orange		2222NCORANGE	2223NCORANGE
Red		2222NCRED	2223NCRED
Blue		2222NCBLUE	2223NCBLUE

9" Diaphragm - Universal 2224, 2226, 2229 & 2231

Finish	9" Single	9" Slim Line	9" Dual	9" Dual w/Y7 rod
Chrome	2226NA	2231NA	2224NA	2229NA
Gold zinc	2226NB	2231NB	2224NB	2229NB
Black			2224NC	2229NC
Yellow	2226NBYELLOW		2224NCYELLOW	
Orange	2226NBORANGE		2224NCORANGE	
Red	2226NBRED		2224NCRED	
Blue	2226NBBLUE		2224NCBLUE	

9" Single Diaphragm - Specific Fit 2225, 2230 & 2233

Finish	Corvette 63-67	Nova 62-67	Mustang 67-70	Jeep CJ 74-86*
Chrome	2230NA	2233NA	2225NA	2231NAJ
Gold zinc	2230NB	2233NB		2231NB
Black			2225NB	

* 9" Slim Line diaphragm - includes mounting bracket

11" Diaphragm 2227, 2228 & 2232

	Universal	73-93 GM Truck
Finish	11" Single	11" Dual
Chrome	2227NA	2232NA
Chrome w/studs	2228NA	
Gold zinc	2227NB	
Gold zinc w/studs	2228NB	
Black		2232NB
Yellow	2227NBYELLOW	
Orange	2227NBORANGE	
Red	2227NBRED	
Blue	2227NBBLUE	

2227N and 2232N include booster mounting bracket

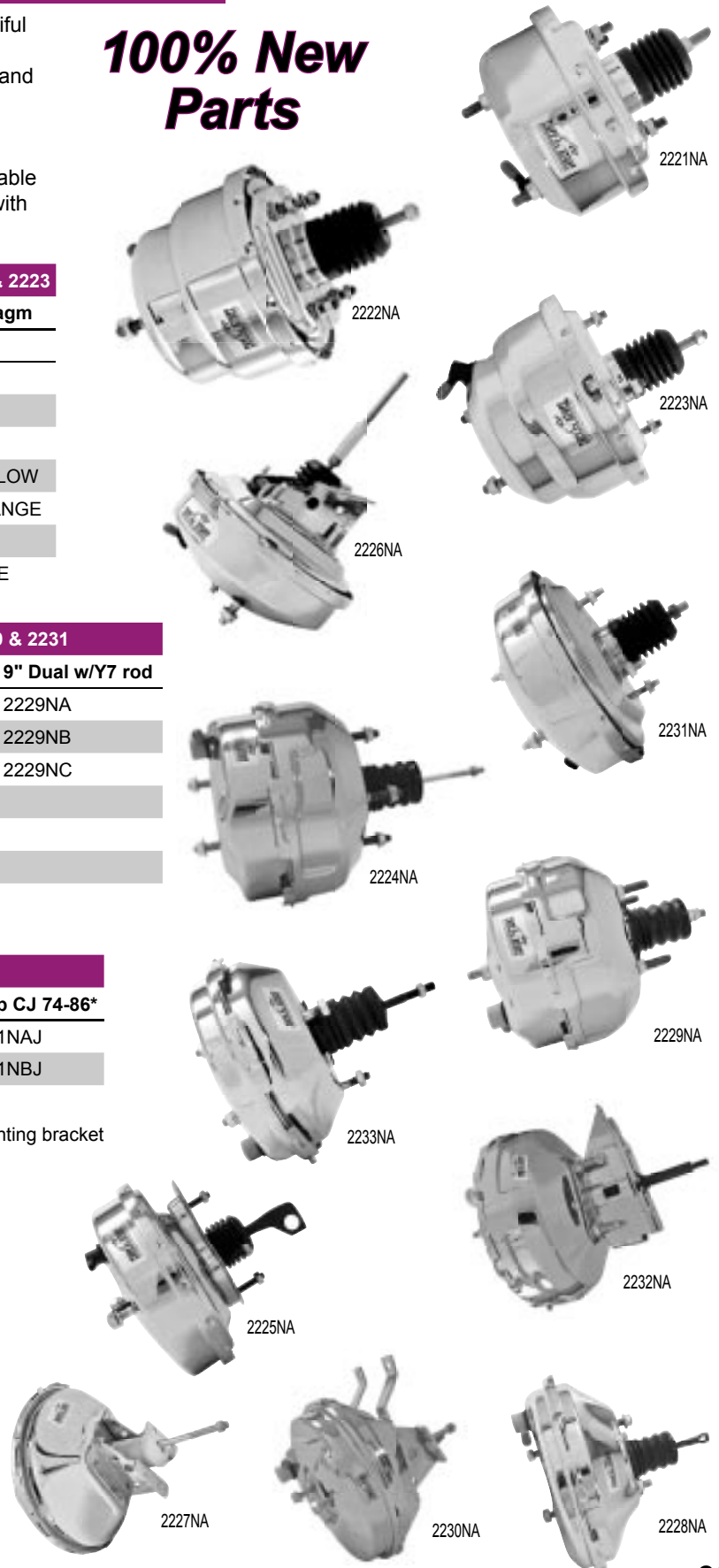



Master Cylinders

OUR CHROME WILL GET YOU HOME!



2018, 2019, 2071, 2072



2020, 2021



2017

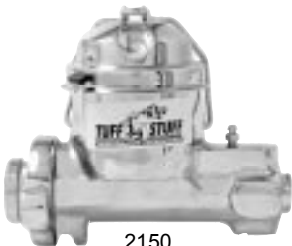

2150



2035

Master Cylinders

- Stock style cast iron master cylinders fit virtually all hot rods, customs & muscle cars
- Available in a variety of finishes including chrome plated, powder coated or as cast
- 1" Master cylinder bore recommended for disc/drum, and drum/drum brake set-ups
- 1-1/8" Master cylinder bore recommended for most disc/disc brake set-ups
- 100% new components – not remanufactured

Universal Applications - Cast Iron Master Cylinders

Ports	9/16" & 1/2" Driver side, 1" bore		9/16" & 1/2" Driver side, 1-1/8" bore	
	Shallow	Deep	Shallow	Deep
Chrome	2018NA	2019NA	2071NA	2072NA
Black	2018NC	2019NC	2071NC	2072NC
Yellow			2071NCYELLOW	
Orange			2071NCORANGE	
Red			2071NCRED	
Blue			2071NCBLUE	
As cast	2018NB	2019NB	2071NB	2072NB

100% New Parts

Dedicated Applications - Cast Iron

Application	Heavy Duty Corvette		Ford Mustang	Mopar	Universal Fruit Jar*
Ports	Two 3/8" ports, both sides, 1" bore		3/8"-24 & 1/2"-20 ports	9/16" & 1/2"	Two 7/16-24 ports
Finish	Shallow	Deep	1" Bore	1-1/8" Bore	Shallow, 1" bore
Chrome	2020NA	2021NA	2017NA	2035NA	2150NA
Black	2020NC				
Yellow	2020NCYELLOW		2017NBYELLOW		
Orange	2020NCORANGE				
Red	2020NCRED		2017NBRED		
Blue	2020NCBLUE		2017NBBLUE		
As cast	2020NB	2021NB	2017NB	2035NB	2150NB

*Single reservoir for drum/drum style brakes

2020, 2021 and 2150 have 3-1/2" mounting hole spacing, 2017 has 3-1/8" mounting bolt spacing,

2035 has 3-1/4" mounting hole spacing

See page 46-47 for master cylinder dimension

NEW!



Master Cylinder Rebuild Kits

- Includes all of the seals and small parts needed to rebuild Tuff Stuff master cylinders

Master cylinder rebuilding kits

Bore	Part#
1"	2020123
1-1/8"	2071123

Master Cylinders

- Aluminum Smoothie style master cylinders fit virtually all hot rods, customs & muscle cars
- Beautiful chrome plated or polished finish
- 1" Master cylinder bore recommended for disc/drum, and drum/drum brake set-ups
- 1-1/8" Master cylinder bore recommended for most disc/disc brake set-ups
- Dual reservoir with 3-1/2" mounting bolt spacing
- 100% all new components – not remanufactured

**100% New
Parts**

*Aluminum
Smoothie*

Aluminum Smoothie Master Cylinders

Ports	9/16" & 1/2" Driver side, 1" bore		Two 3/8" - Both Sides, 1" bore		9/16" & 1/2" Driver side, 1-1/8" bore	
Finish	Shallow hole	Deep hole	Shallow hole	Deep hole	Shallow hole	Deep hole
Chrome	2023NC	2024NC	2025NC	2026NC	2027NC	2028NC
Polished	2023NA	2024NA	2025NA	2026NA	2027NA	2028NA



2023, 2024, 2027, 2028



2025, 2026

Alkyd Engine Enamel Paint

Alkyd Engine Enamel Paint

Color	Part#
Red	9001
Orange	9002
Yellow	9003
Blue	9004

- Color coordinate your engine compartment with Tuff Stuff's alkyd engine enamel
- Perfect color match to Tuff Stuff's powder coated accessories
- Available in red, orange, yellow or blue in pint size cans
- Provides a refreshing new underhood look



All polishing, chrome plating and powder coating is done in house – in Cleveland, Ohio – along with assembly and Tuff testing of every unit!





Booster Brackets

OUR CHROME WILL GET YOU HOME!



4750

Universal Brake Booster Extension Rod and Clevis Kit 4750

- Fits Booster combos 2121, 2122 and 2123
 Fits Power brake boosters 2221, 2222 and 2223
- Adapts most factory brake setups to Tuff Stuff boosters, plain finish, #4750



4650A

Universal GM 1967-72 Brake Booster Brackets 4650

- Fits Booster combos 2121N, 2122N and 2123N
 Fits Power brake boosters 2221N, 2222N and 2223N
- Available in chrome plated or gold zinc and in a variety of colors
 - Made from heavy gauge steel
 - Includes left and right brackets

GM 1967-72

Finish	Part#
Chrome	4650A
Gold zinc	4650B
Black	4650C
Yellow	4650BYELLOW
Orange	4650BORANGE
Red	4650BRED
Blue	4650BBLUE



4651A

Universal GM 1955-64 Brake Booster Brackets 4651

- Fits Booster combos 2121N, 2122N and 2123N
 Fits Power brake boosters 2221N, 2222N and 2223N
- Available in chrome plated or gold zinc and in a variety of colors
 - Made from heavy gauge steel
 - Includes left and right brackets

GM 1955-64

Finish	Part#
Chrome	4651A
Gold zinc	4651B
Black	4651C
Yellow	4651BYELLOW
Orange	4651BORANGE
Red	4651BRED
Blue	4651BBLUE



4652A

Universal GM 1955-58 Brake Booster Brackets 4652

- Fits Booster combos 2121N, 2122N and 2123N
 Fits Power brake boosters 2221N, 2222N and 2223N
- Available in chrome plated or gold zinc and in a variety of colors
 - Made from heavy gauge steel
 - Includes left and right brackets

GM 1955-58

Finish	Part#
Chrome	4652A
Gold zinc	4652B
Black	4652C
Yellow	4652BYELLOW
Orange	4652BORANGE
Red	4652BRED
Blue	4652BBLUE

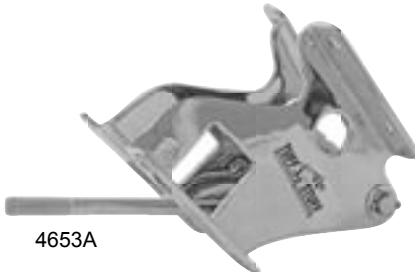

4653A

Universal GM Truck 1960-72 Brake Booster Brackets 4653

- Fits Power brake boosters 2222N, 2223N, 2224N, 2228N
 Fits Booster combos 2122N, 2123N, 2124N, 2128N
- Works with 2 hole OEM bracket setups late 1967 through 72
 - Includes pedal rod

GM Truck 1960-72

Finish	Part#
Chrome	4653A
Plain	4653B



4632A

Universal GM Truck 1973-93 Brake Booster Brackets 4632

- Fits Power brake boosters 2232
 Fits Booster combos 2132
- Works with 6 hole OEM pattern

GM Truck 1973-93

Finish	Part#
Chrome	4632A
Plain	4632B

Universal Ford Mustang Brake Booster Brackets 4655

Mustang brackets

Finish	Part#
Chrome	4655A
Plain	4655B

Fits Power brake boosters 2221
Fits Booster combos 2134
Includes pedal rod assembly



4655B

Universal Jeep CJ 1974-86 Brake Booster Brackets 4656

Jeep CJ 1974-86

Finish	Part#
Chrome	4656A
Gold Zinc	4656B

Fits Power brake boosters 2231
Fits Booster combos 2131
Includes pedal rod assembly

Universal Dodge 1965-74 Brake Booster Brackets 4654

Dodge 1965-74

Finish	Part#
Chrome	4654A
Plain	4654B

Includes pedal rod assembly



4654A

Proportioning Valves Kits 2301, 2302, 2303, 2304

Proportioning Valves

Finish	Disc/Drum		Disc/Disc
Master	2020, 2021, 2023	2018	2027, 2028
Cylinders	2024, 2025, 2026	2072	2071, 2072
Chrome	2301NA	2302NA	2303NA
Brass	2301NB	2302NB	2303NB

Match your master cylinder number to the proportioning valve

Includes OE style mounting bracket, two short brake lines, proportioning valve with brake light switch with wire terminal and fasteners

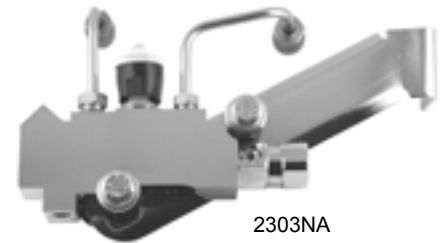

2303NA

Loaded Brake Calipers 2242, 2243

Loaded brake calipers

Finish	Large caliper	Mid-size caliper
Chrome	2242A	2243A
Black	2242B	2243B
Plain	2242C	2243C
Parts kit	2259	2258

2242 Fits Large GM caliper applications w/7" bolt spacing
2243 Fits mid-size GM caliper applications originally 1969-74 GM

- Calipers are loaded with high-performance, low-dust brake pads
- Includes chrome plated hardware, sold in pairs
- Both large and mid-size calipers have a 7" bolt spacing
- Small parts kit sold separately

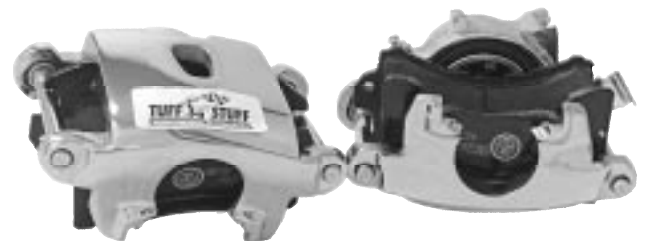



Booster Dimensions

OUR CHROME WILL GET YOU HOME!

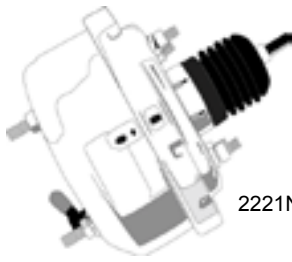

2221N

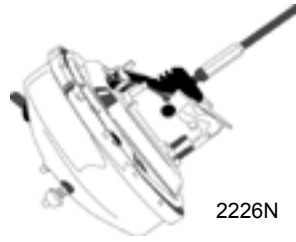

2226N

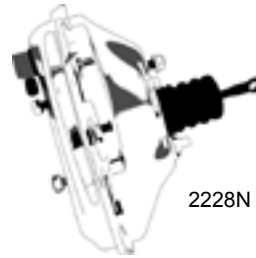

2228N



2230N

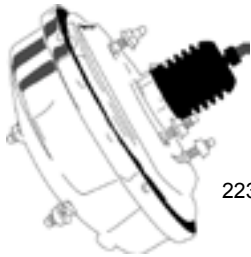

2231N

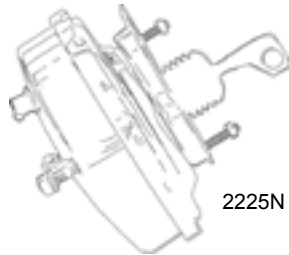

2225N

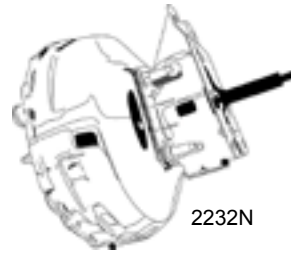

2232N



2223N



2233N

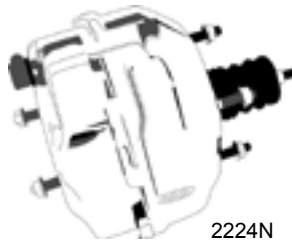

2224N

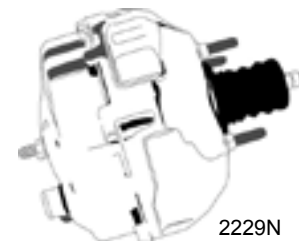

2229N

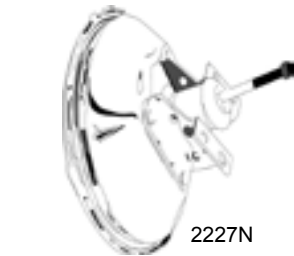

2227N



2222N

Power Brake Booster Dimensions

Part#	Description	Booster Length	Rod Length	Mounting	Details
Power Brake Booster Only - No Master Cylinder					
2221N	7" Single diaphragm	3.50"	4.00"	4 studs	
2222N	7" Dual diaphragm	5.25"	4.00"	4 studs	
2223N	8" Dual diaphragm	5.25"	4.00"	4 studs	
2224N	9" Dual diaphragm	6.00"	5.25"	4 studs	
2225N	Ford Mustang 67-70, 9" single diaphragm	3.75"	3.12"	4 studs	Offset studs
2226N	GM A & F body 64-66, 9" single diaphragm	6.50"	1.50"	4 holes	1.5" past bracket
2227N	GM A & F body 66-72, 11" single, w/bracket	6.50"	7.12"	4 holes	Angle booster bracket
2228N	11" Single diaphragm w/studs	4.25"	4.62"	4 studs	4.62" from mounting surface to center of eyelet
2229N	Corvette 68-82, 9" dual diaphragm, w/Y-7 rod	6.00"	4.12"	4 studs	
2230N	Corvette 63-67, 9" single diaphragm	6.25"	3.12"	bracket w/2 studs	
2231N	9" Single diaphragm Slim line	4.00"	3.81"	4 studs	
2232N	GM Truck 73-92, 11" dual diaphragm	8.50"	3.25"	4 holes	
2233N	Nova 62-67, 9" single diaphragm	4.25"	5.25"	3 studs	



Every power brake booster unit is hand assembled and tested to assure quality and long life dependability.

**OUR CHROME WILL
GET YOU HOME!**

Master Cylinder Booster Dimensions



2121N

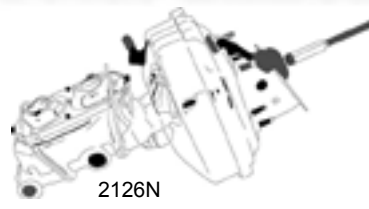

2126N

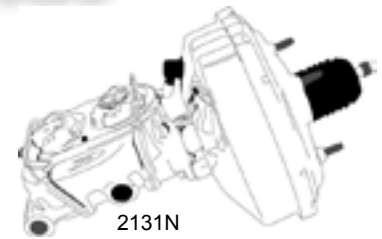

2131N



2122N



2127N

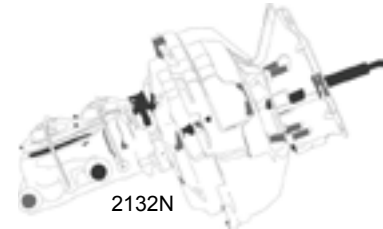

2132N



2123N

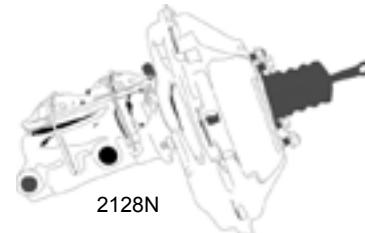

2128N

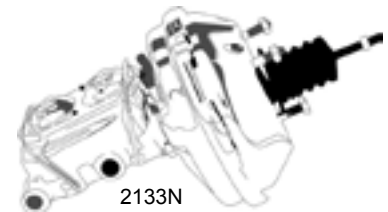

2133N

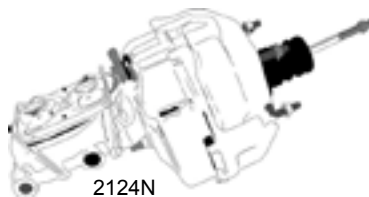

2124N

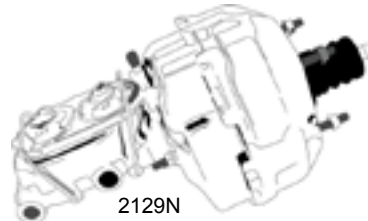

2129N

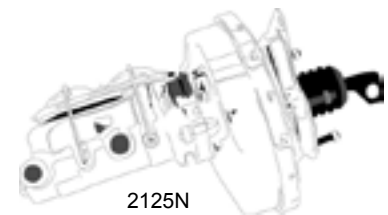

2125N

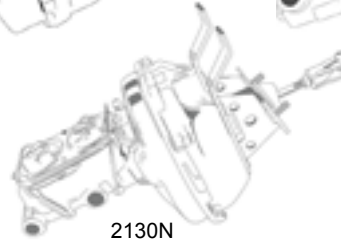

2130N

*Note that all 4-stud booster and
combo mounts feature a 3-1/2"
square centerline mounting pattern*

Master Cylinder / Power Brake Booster Combo Dimensions

Part#	Description	Master Cylinder Length	Booster Length	Rod Length	Mounting	Details
Universal Master Cylinder w/Power Brake Booster Combo						
2121N	7" Single diaphragm combo	8.00"	3.50"	4.00"	4 studs	
2122N	7" Dual diaphragm combo	8.00"	5.25"	4.00"	4 studs	
2123N	8" Dual diaphragm combo	8.00"	5.25"	4.00"	4 studs	
2124N	9" Dual diaphragm combo	8.00"	6.00"	5.25"	4 studs	
2128N	11" Single w/studs diaphragm combo	8.00"	4.25"	4.62"	4 studs	4.62" from mounting surface to center of eyelet
2131N	9" Single diaphragm Slim line w/studs combo	8.00"	4.00"	3.81"	4 studs	
Dedicated Master Cylinder w/Power Brake Booster Combo						
2125N	Mustang 67-70, 7" single diaphragm w/bracket combo	7.50"	3.75"	3.12"	4 studs	Offset studs
2126N	GM A & F body 64-66, 9" single diaphragm w/bracket combo	8.00"	6.50"	1.50"	4 holes	1.5" past bracket
2127N	GM A & F body 66-72, 11" single diaphragm w/bracket combo	8.00"	6.50"	7.12"	4 holes	Angle booster bracket
2129N	Corvette 68-82, 9" dual diaphragm W/Y-7 rod combo	8.00"	6.00"	4.12"	4 studs	
2130N	Corvette 63-67, 9" single diaphragm w/bracket combo	8.00"	6.25"	3.12"	bracket w/2 studs	
2132N	GM Truck 73-92, 11" dual diaphragm combo	8.00"	8.50"	3.25"	4 holes	Bracket angled from 2.75" at top to 3.0" at bottom
2133N	Nova 62-67, 9" single diaphragm combo	8.00"	4.25"	3.25"	4 holes	