



Starters

**OUR CHROME WILL
GET YOU HOME!**

GM OE Style Starter (Full-Size Case) 3510, 3570, 3631, 3689



- Available with a chrome plated or powder coated body
- All-new components including heat treated shaft, specially wound copper armature and a high temperature solenoid
- 100% quality tested
- Includes starter shims
- Chrome nose (front casting) available at extra cost

3510, 3570 and 3689 starters fit 168 tooth flywheels
3631 starter fits 153 tooth flywheel

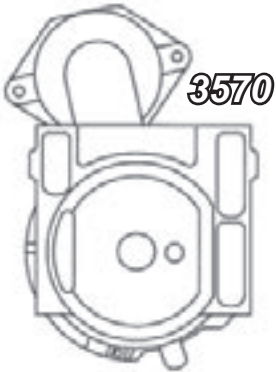

3570

**See Gear Reduction Upgrades
3193, 6510, 6550, 6584, 6772 on
pages 17 and 18**



3510

3510	Chevy Full Size
Finish	w/staggered bolts
Chrome	3510A
Chrome	3510NA
Chrome*	3510AC
Black	3510B
Black	3510NB
Yellow	3510BYELLOW
Orange	3510BORANGE
Red	3510BRED
Blue	3510BBBLUE

* With chrome nose

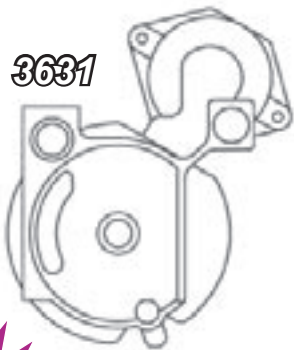

3631

3631	GM - some Cadillac, Chevy, Olds & Pontiac
Finish	w/straight bolts, 1 long & 1 short
Chrome	3631A
Black	3631B

3689	GM w/manual trans
Finish	Cast iron nose
Chrome	3689A
Black	3689B

3570	Olds Full Size
Finish	w/2 long straight bolts
Chrome	3570A
Black	3570B



NEW!

GM LS1 Starter 6492

Fits 1998-2001 Camaro & Firebird, 1997-2004 Corvette with the GM LS1, LS2 & LS6 engine

- Use on 153 or 168 tooth flywheels
- Available in chrome or gold zinc plated
- 1.9 HP gear reduction motor will turn up to 12:1 compression ratio

6492	GM LS1
Finish	w/2 long bolts
Chrome	6492A
Gold zinc	6492B

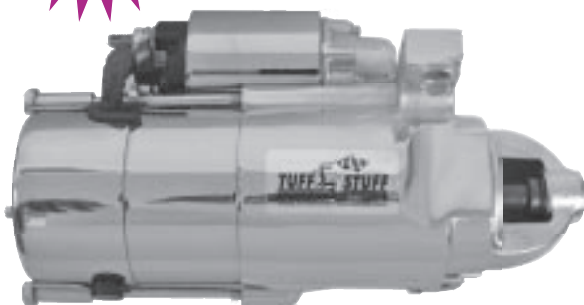

GM PMGR Style Starter 6510, 6631

- Latest permanent magnet gear reduction technology
- Available with a black or chrome body and nose
- 4.4:1 Gear reduction provides up to 150 ft lbs of torque
- Weighs only 9 lbs, bolts and shims included
- Use on only 168 tooth flywheels

PMGR

Chevy starter with staggered mounting bolts

Finish	Part#
Chrome	6510NA
Black	6510NB

1993-95 Camaro & Firebird w/ 5.7 engine, straight mounting bolts

Finish	Part#
Chrome	6631NA
Black	6631NB



GM Super Mini Gear-Reduction Starter 6772

- Larger starter motor means more available torque for those higher compression engines
- Available in chrome or black
- 2.6 HP Super gear reduction motor will crank up to 18:1 compression ratio
- Front block is adjustable to allow for oil pan and header clearance
- Use on 153 or 168 tooth flywheels
- Bolts and shims included

Super

Chevy starter with straight mounting bolts

Finish	Part#
Chrome	6772A
Black	6772B

Bolt & Shim Kit Included

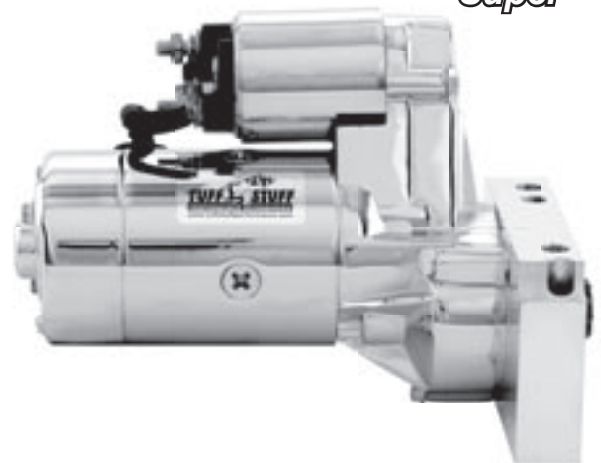

Super Lite

GM Super-Lite Mini PMGR Starter 6550

- Super compact size
- Available in chrome or black
- 6.1 to 1 Permanent magnet gear reduction
- 1.6 HP will crank up to 11:1 compression engines
- Front block is adjustable to allow for oil pan and header clearance
- Use on 153 or 168 tooth flywheels
- Bolts and shims included

GM

Finish	Part#
Chrome	6550A
Black	6550B



360 Indexing

Only 7lbs



Starters

OUR CHROME WILL GET YOU HOME!

Chevy Mini Gear-Reduction Starter 6584

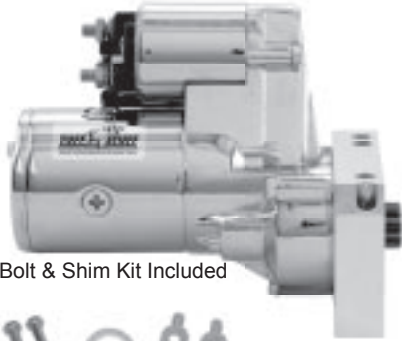

Bolt & Shim Kit Included



- 1.9 HP gear reduction starter will turn up to 12:1 compression ratio
- Front block is adjustable to allow for oil pan and header clearance
- Use on 153 or 168 tooth flywheels
- Available in chrome plated or 5 powder coated colors
- Includes mounting bolts and shims

Chevy w/straight mounting bolts

Finish	Part#
Chrome	6584A
Black	6584B
Yellow	6584BYELLOW
Orange	6584BORANGE
Red	6584BRED
Blue	6584BBLUE

Upgrade to 6772 on page 17

GM Mini Denso-Style Starter 3193

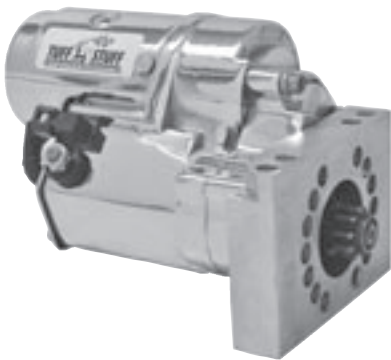

- Will crank up to 15:1 compression engines
- 6 Position index block allows adjustment for oil pan and header clearance
- Use on 153 or 168 tooth flywheels
- Available in chrome or black
- Includes mounting bolts and shims

Chevy w/straight mounting bolts

Finish	Part#
Chrome	3193NA
Black	3193NB

Olds/Pontiac Mini Gear-Reduction Starter 6586



- 40% lighter and 1/3 smaller than OE
- 1.9 HP, 3.75:1 Gear reduction
- Front block is adjustable to allow for oil pan and header clearance
- Unaffected by heat and available in chrome or black
- Includes mounting bolts and shims
- Fits Olds and Pontiac 330-455 V8 engines using a stock ring gear and flexplate. Does not fit 6.6L engine

Olds and Pontiac

Finish	Part#
Chrome	6586A
Black	6586B

Super

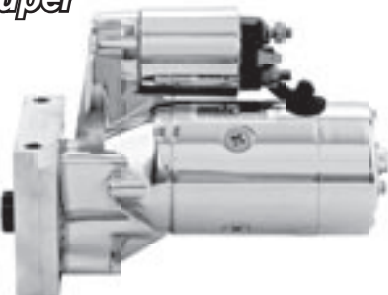

Olds/Pontiac Super Mini Gear-Reduction Starter 6786

- The ultimate in high-torque gear reduction starters
- 2.6 HP motor is unaffected by heat
- Front block is adjustable to allow for oil pan and header clearance
- Includes mounting bolts and shims
- Available in chrome or black
- Fits Olds and Pontiac 330-455 V8 engines using a stock ring gear and flexplate. Does not fit 6.6L engine

Olds and Pontiac

Finish	Part#
Chrome	6786A
Black	6786B

Chevy, BOP PMGR Gear-Reduction Starter 6431



Chevy, Buick, Olds, Pontiac	
Finish	Part#
Chrome	6431NA
Gold zinc	6431NB

- Latest permanent magnet gear reduction technology
- Includes mounting bolts and shims
- Available in chrome or gold zinc plated
- Chevy, Buick, Olds, Pontiac with 3.4 & 3.8L engine w/1 long & 1 short bolt



Ford OE Direct Drive Starter 3124, 3131, 3132, 3149

- 3124 Fits 1963-91 289,389,302,351 CID with auto trans - 2 bolt
- 3131 Fits 1966-81 F.E. engines only 255,352,390,427,428 CID with 3 bolt auto or manual trans
- 3132 Fits 1965-74 289,302,351 CID with manual trans - 2 bolt
- 3149 Fits 1969-77 351, 400, 429 CID w/2 bolt holes -1 hole is threaded
- 3160 Fits 1978-80 L6 200 CID w/auto trans
- Full size direct drive OE style starter features 100% new construction

Trans	Auto	Manual	Auto or Manual	
Finish	2 Bolt	2 Bolt	3 Bolt	2 Bolt*
Chrome	3124A	3132A	3131A	3149A
Black	3124B	3132B	3131B	3149B
Yellow	3124BYELLOW			
Blue	3124BBBLUE			
Plain	3160B			



2 bolt



3 bolt



*3149 has 2 bolt holes - 1 is threaded
Upgrade 3124 to 6124, 6585 or 6785 below
Upgrade 3132 to 6132 below

PMGR

Ford Direct Drive PMGR Starter 6124, 6131, 6132

- 6124 Fits 1963-91 289,389,302,351 auto trans - 2 bolt, 1992-95 Mustang and 1991-93 Thunderbird 5.0L with auto trans
- 6132 Fits 1965-74 289,302,351 CID with manual trans. (2 bolt)
- Planetary gear design increases torque and weighs only 10 pounds

Trans	Auto	Manual	Auto or Manual
Finish	2 Bolt	2 Bolt	3 Bolt
Chrome	6124A	6132A	6131A
Black	6124B	6132B	6131B

Upgrade to 6585 or 6785 - see below and next page

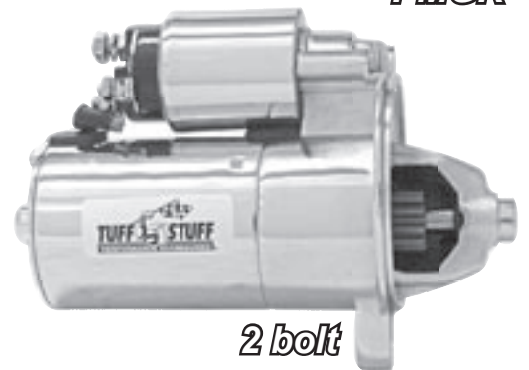

2 bolt

Ford Super-Mini Starter 6785

Ford Super-Mini	
Finish	Part#
Chrome	6785A
Black	6785B

- Fits 221 to 351 small blocks with automatic trans. Also fits Arias/Root 429 big block
- The ultimate in high-torque gear reduction starters
- 40% lighter and 1/3 smaller than OE
- 2.6 HP motor is unaffected by heat
- 3.75:1 gear reduction produces 50% more torque
- Increased header chassis and oil pan clearance

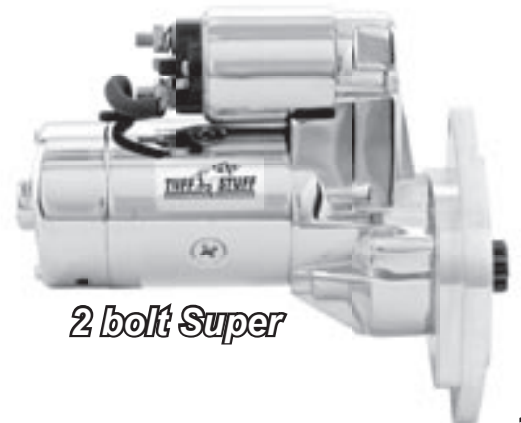

2 bolt Super



Starters

**OUR CHROME WILL
GET YOU HOME!**

Ford Mini Gear-Reduction Starter 6585

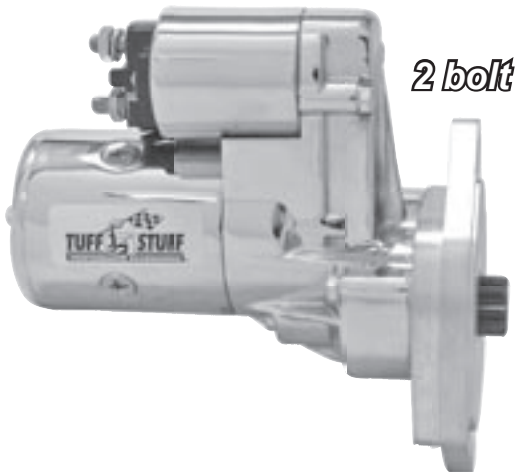

2 bolt

- 1.9 HP starter motor is unaffected by heat
- 3.75:1 gear reduction produces 40% more torque
- Increased header chassis and oil pan clearance
- Fits 221 to 351 small blocks with automatic trans.
- Also fits Arias/Root 429 big block

Ford Mini Gear-Reduction

Finish	Part#
Chrome	6585A
Black	6585B
Yellow	6585BYELLOW
Red	6585BRED
Blue	6585BBLUE
Upgrade to 6785	

Ford PMGR Starter 6221

PMGR



3 bolt

- 3.75:1 planetary gear reduction provides 40% torque increase
- Weighs only 10 lbs
- Fits Ford applications below with a 3 bolt starter

Ford PMGR

Finish	Part#
Chrome	6221A
Black	6221B

Fits:

1992 - 09 Ford Crown Victoria 4.6L
 1997 - 09 Ford E Series Van 4.6L, 5.4L, 6.8L
 1997 - 98 Ford F Series Pickup 4.6L, 5.4L
 1993 - 98 Lincoln Mark VIII 4.6L
 1992 - 09 Lincoln Town Car 4.6L
 1992 - 09 Mercury Grand Marquis 4.6L

1996 - 04 Ford Mustang 4.6L
 1997 - 98 Ford Expedition 4.6L, 5.4L
 1994 - 97 Ford Thunderbird 4.6L
 1998 Lincoln Navigator 5.4L
 1994 - 97 Mercury Cougar 4.6L
 2003 - 04 Mercury Marauder 4.6L

Ford PMGR Noseless Starter 6646



- Triple chrome plated or gold zinc plated
- Heavy duty OE performance, torque & output
- High performance rare earth magnets for maximum torque
- Planetary gears feature needle bearings rather than bushings
- Solenoids feature late style S-terminal with threaded post & include a spade terminal conversion kit
- 100% New

Ford PMGR Starter

Finish	Part#
Chrome	6646A
Gold zinc	6646B

Fits:

2000-05 Ford Excursion 5.4L, 6.8L
 1999-09 Ford Expedition 5.4L
 1999-09 Ford F Series Pickup 5.4L, 6.8L
 2007-09 Ford Mustang 5.4L
 2006-08 Lincoln Mark LT 5.4L

1999-04 Ford Expedition 4.6L
 1999-08 Ford F Series Pickup 4.6L
 2005-09 Ford Mustang 4.6L
 2002 Lincoln Blackwood 5.4L
 1999-09 Lincoln Navigator 5.4L

Mopar

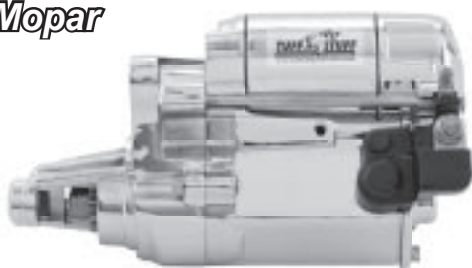

Chrysler Denso-Style Starter 6084

- Gear reduction starter weighs only 9 lbs and provides twice the torque
- Motor is unaffected by heat
- Provides increased header chassis and oil pan clearance
- Can fit Hemi with an aftermarket adaptor - not available from Tuff Stuff
- Fits 1965-83 225, 273, 318, 340, 360, 361, 383, 400, 426 and 440 CID engines

Chrysler Denso-Style

Finish	Part#
Chrome	6084A
Gold zinc	6084B



AMC/Jeep Full Size Starter 3211

AMC/Jeep	
Finish	Part#
Chrome	3211NA
Black	3211NB

- Available with a chrome plated or powder coated body
- All-new components including heat-treated shaft, specially wound copper armature and a high-temperature solenoid
- 100% quality tested



3211NA

Starter Repair Kit 7584

Starter Repair Kit	
Description	Part#
Complete rebuild kit, full spline	7584A
Full spline pinion	7584C
Clutch assembly	7584E
Mounting block	7584F
Solenoid	7584G
Chrome solenoid	7584GA

- Rebuild parts and kit for Tuff Stuff mini-starter 6584
- Complete kit includes full-spline pinion



7584A

Hot Start Kit 7629

- Eliminates slow cranking due to excessive engine heat
- Give your starter an extra 12 volt boost
- Ideal for GM full-size OEM starters

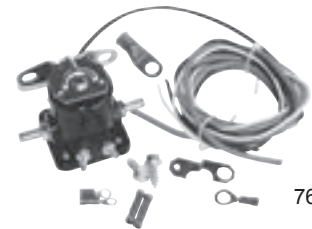

7629

Shim and Bolt Kit 7633

- Same shim kit that is included with most Tuff Stuff mini starters
- Ensures proper flywheel ring gear clearance on 6584 and 6772 starters



7633

Chrome Starter Kit 7550

7550A fits most GM Chevy, Buick, Cadillac, Olds & Pontiac OEM starters 3510, 3570 & 3631

Chrome Starter Kit	
Application	Part#
GM	7550A

- Chrome plate your original starter with that awesome Tuff Stuff chrome plated finish
- Provides the look of a chrome plated starter without having to buy a new starter



7550A

Starter Bolts 7623

Fits most full size Chevy, Buick, Olds and Pontiac and Tuff Stuff 3510 & 3570 starters with 4-5/8" x 3/8-16" bolts

Chrome Starter Bolts	
Finish	Part#
Chrome	7623A
Gold zinc	7623B

- Original style starter mounting bolts correct starter to engine alignment
- Frequently eliminates chattering problems arising from worn-out bolts
- 2 Bolts per set



7623