



# TYPE II POWER STEERING PUMP DIMENSIONS

Tuff Stuff Type II power steering pumps are available with various port and fitting configurations, threaded or thru hole mounting options and in a wide variety of finishes. For complete product information or to watch our [power steering pump video](#), visit our web site [www.tuffstuffperformance.com](http://www.tuffstuffperformance.com)

All Type II power steering pumps have a 0.665" shaft diameter except for the 6175ALD-6, 6175ALP-6, 6175ALB-6 and the 6175AL-6 LS pumps, which have a 19mm shaft diameter. All Type II pumps require a press-on pulley and have a 3/8"-16 tapped center shaft.

### Rotation - viewed from the shaft end

All Type II power steering pumps are designed to rotate **CLOCKWISE** except for the 6169 series which is designed to rotate counter-clockwise.

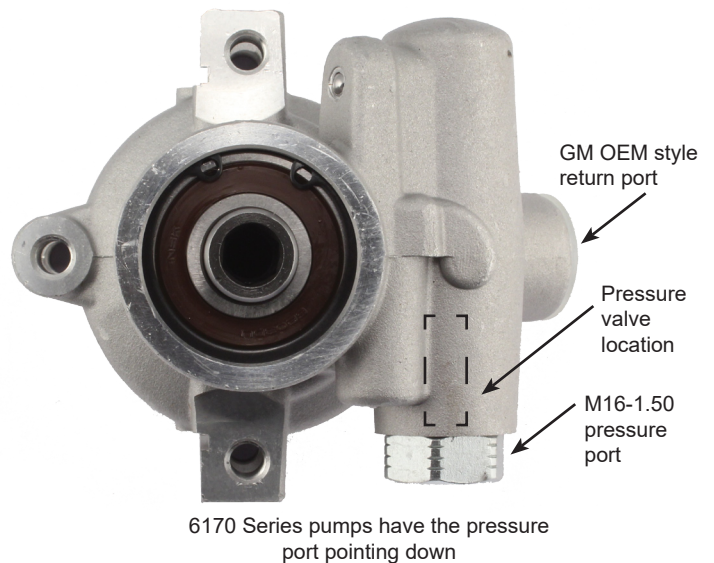
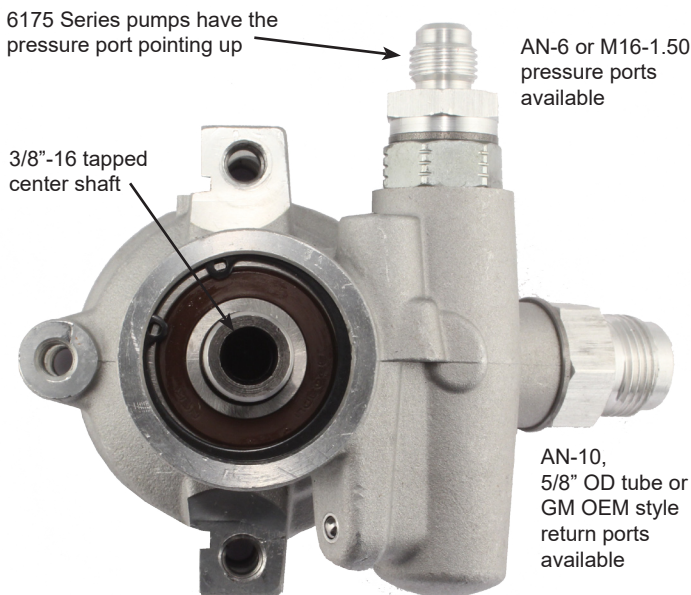
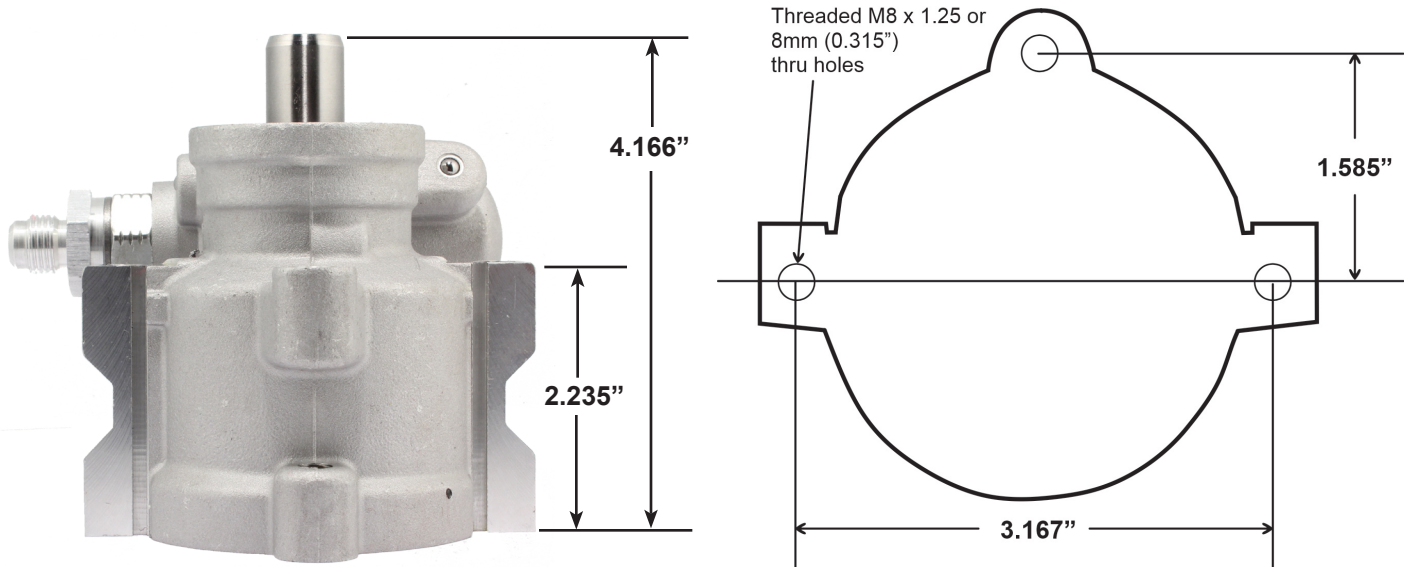

All Type II pumps have a 1200 PSI pressure and 3GPM flow rating. An optional 850PSI 2GPM valve is available separately.