

NOTE: If your pump has a stud at the lower rear pivot point, remove it and use the 1" bolt and .150" spacer.

We use a belt length of 37 to 38" with this mount on installations in our shop. However; this can vary with the diameter of your pulleys.

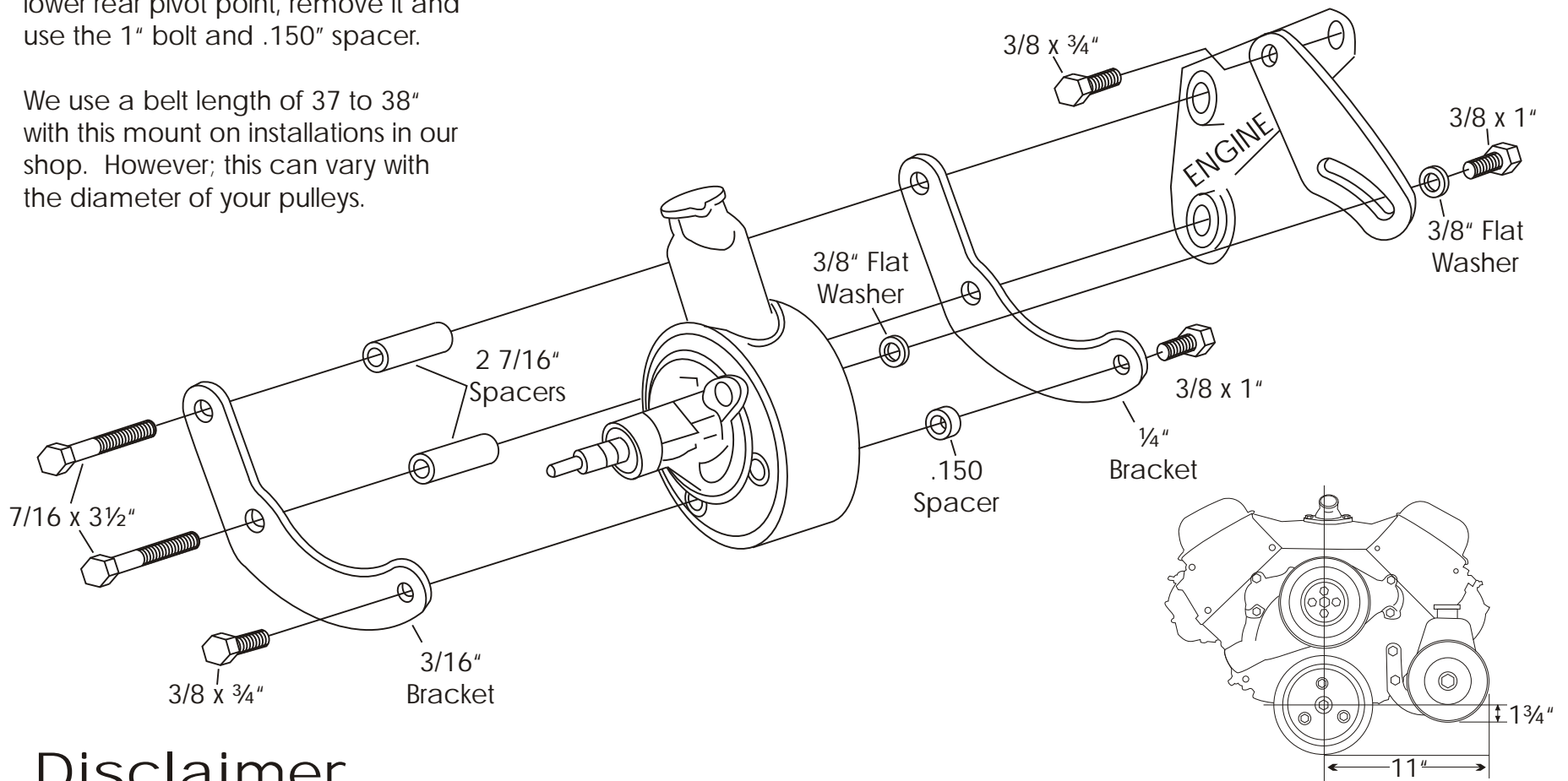

## Disclaimer

- The purchaser is responsible for determining the suitability of any or all products purchased from Tuff Stuff Performance Accessories LTD.
- The customer recognizes that Tuff Stuff products may not be a direct replacement for their original, and some modifications may be necessary.
- Tuff Stuff will not influence your use of this product in your vehicle in any manner.
- Any Tuff Stuff product shall be installed at your own discretion.
- Remember: Any Tuff Stuff product must be installed by a professional mechanic.
- Chrome plated products returned for proposed warranty with scratches or chips will not be considered for refund or replacement.



Power Steering  
Pump Mount

6503A

6503B

Big Block Chevy - Driver's Side  
Short Water Pump